



COPAN WASP® DT: **WALK-AWAY SPECIMEN PROCESSOR** »»

Technical Specifications

MicroScan Microbiology Systems



»» Move healthcare forward.

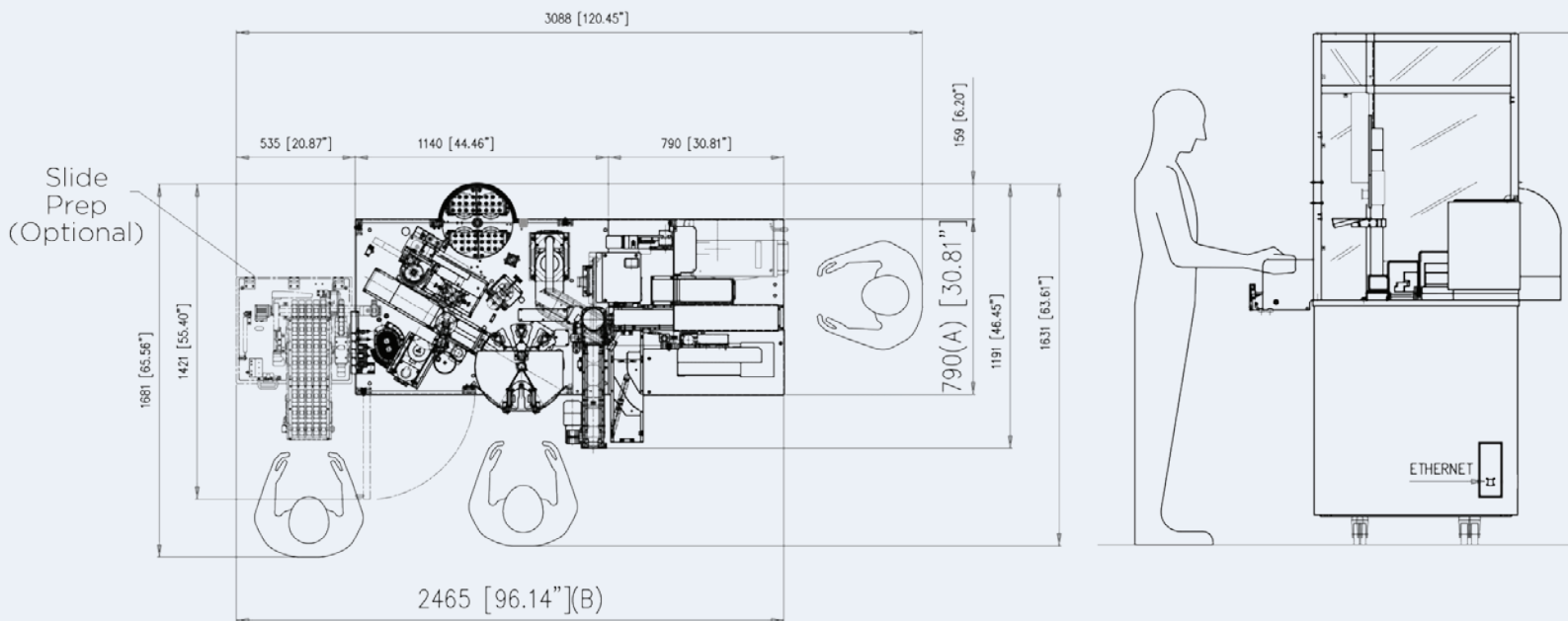

Basic standard WASP DT instrument specifications

- > 9 silo carousels for plated media with a capacity of 324–378 culture plates
- > Average rate of 130 plates streaked per hour
- > Duplex plating software uploaded
- > 1 vortex device
- > 1 centrifuge spinner
- > 1 universal decapping system and docking station
- > 1 plate label printer
- > Bar code reading systems for specimen and plate labels (2 readers for bottom or 1 reader for side plate labelling)
- > 1 touch screen monitor, keyboard, and mouse
- > 1 specimen-sampling verification system (camera and image analysis software)
- > 1 WASP software (including upgrades for first year of ownership)
- > 1-year warranty, technical assistance and spare parts supplied by Beckman Coulter

Standard items included with purchase of WASP DT instrument (start-up kit)

- > 8 specimen pallets for Copan container type (Copan ESwab™ & broth containers, capacity of 12 containers per pallet)
- > 2 Biquetra inoculation loops (1 µL)
- > 2 Biquetra inoculation loops (10 µL)
- > 2 Biquetra inoculation loops (30 µL)
- > Loop adjustment guide tool
- > 2 rolls of plate labels (side or bottom, depending on option selected)
- > 1 SATO bar code printer ink roll
- > 1 box of disposable drip trays (24 pcs)
- > 1 box of disposable rejection bin pads (40 pcs)
- > 1 box of disposable docking station splash protective pads (24 pcs)
- > 1 box of loop cleaning solution (50 pcs)
- > 1 set of urine cup specimen processing tools (cradle and guide rails, only supplied with the purchase of the urine turntable option)

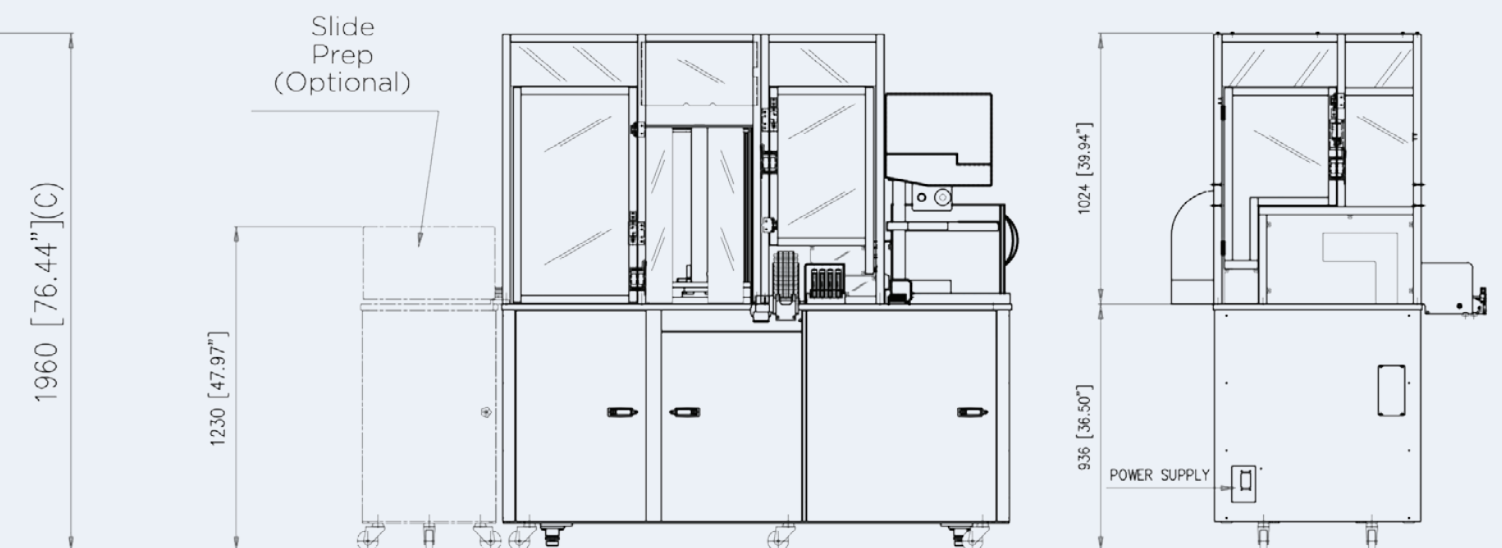

Additional WASP DT accessories/modules (sold separately)

- > Automatic loop change
- > Sort-out plate stacker for plate sorting according to incubation conditions
- > Additional pallet types (for container types different from Copan 12)
- > Turntable for big urine containers
- > Twin Loop kit module for biplate streaking (complete with 2-loop cleansing solution tube holders in the wash station, double incinerator, and all control mechanisms)
- > Broth inoculation module
- > Gram SlidePrep™ module
- > Kirby Bauer inoculation module

Additional start-up kit items

- > 2 Biquetra Twin inoculation loops (1 µL) only supplied with the purchase of the Twin Loop kit module
- > 1 Print Inkjet cartridge only supplied with the purchase of the Gram SlidePrep module
- > Disposable drip tray for slide prep only supplied with the purchase of the Gram SlidePrep module (200 pcs)
- > Slides for microscopy supplied with the purchase of the Gram SlidePrep module (2,000 pcs)

Required consumables for daily operation of the WASP DT instrument

- > Disposable drip trays (checked daily, changed weekly)
- > Disposable rejection bin pads (checked daily, changed weekly)
- > Disposable docking station protective pads (checked daily, changed weekly)
- > Loop-cleaning solution (changed weekly)
- > Bar code labels for plates (4,000 bottom labels or 6,000 side labels)
- > Ink roll for SATO bar code printer (-12,000 labels printed per roll)
- > Inoculation loop—1 µL (up to 15,000 plates for loop, 30,000 for Biquetra)
- > Inoculation loop—10 µL (up to 15,000 plates for loop, 30,000 for Biquetra)
- > Inoculation loop—30 µL (up to 15,000 plates for loop, 30,000 for Biquetra)

TECHNICAL SPECIFICATIONS

GENERAL SPECIFICATIONS

Dimensions	Depth: 46.45" Width: 75.27" Height: 76.44"
Weight	1,700 lbs (approximate)
Electrical Power	208/240VAC; 50/60 Hz; 16A Voltage supply fluctuations shall not exceed $\pm 10\%$ of the nominal supply voltage Peak power at 1500 W max
Temperature (operating)	5°C (41°F) to 40°C (104°F)
Humidity	0 to 95%
Pollution Degree	Degree 2, normal indoor laboratory environment (Air contains only non-conductive pollutants with occasional condensation)
Altitude	Max. 2,000 m (6,561 ft)
Overvoltage Category	Category II, connected to a branch circuit
Network	Ethernet 10/100/1000 MB
Interface	LIS interface available upon request
Peripherals	Touch screen, external bar code reader, label printer
Certifications	CE, CSA, and in compliance with 61010 Standard for Safety for Electrical Equipment for Laboratory Use
Electrical Receptacle	Plug is L620P
Noise Level	Mean level of acoustic pressure @ 1m: LpA=58.5 dB(A); Max level of acoustic pressure: LpA=67.4 dB(A)
Thermal Output	4.761 BTU/hour

WASP PC SPECIFICATIONS*

Hardware	
Producer	ASEM
Model	PB1300
CPU	Intel® Pentium® M760 2 GHz
Video Adapter	GMA900 integrated in Intel 915GME shared 64MB to 128MB system selectable
Network Adapters	2 X 10/100/1000 Mbps (RJ45) controller Intel 82574L
Hard Disk	320GB SATA 2.5"
RAM	2 GB
Serial Ports	9 (1 built-in, 8 Moxa)
Monitor	LCD 17" 4:3 1280:1024 Touchscreen
Software	
Operating System	Linux
Database Engine	SQLITE 3.0

* Specifications subject to change. PC hardware and software provided will be equivalent or better than listed specifications.

Not all products available in all countries.

WASP: Walk-Away Specimen Processor, WASPLab and ESwab are registered trademarks or trademarks of Copan Italia SpA.

BD Vacutainer is a trademark of Becton, Dickinson and Company.

Intel and Pentium are trademarks of Intel Corporation in the U.S. and/or other countries.

All other trademarks are the property of their respective owners.

©2017 Beckman Coulter, Inc. All rights reserved. Beckman Coulter, the stylized logo and the Beckman Coulter product and service names mentioned herein are trademarks or registered trademarks of Beckman Coulter, Inc. in the United States and other countries.

For Beckman Coulter's worldwide office locations and phone numbers, please visit www.beckmancoulter.com/contact

BR-52049



Move healthcare forward.